

新版氣壓控制理論與實務

(附 105 年氣壓乙級術科試題詳解) — 勘誤表



圖 1-22 模式 a SFC 圖



圖 1-44 模式 b SFC 圖

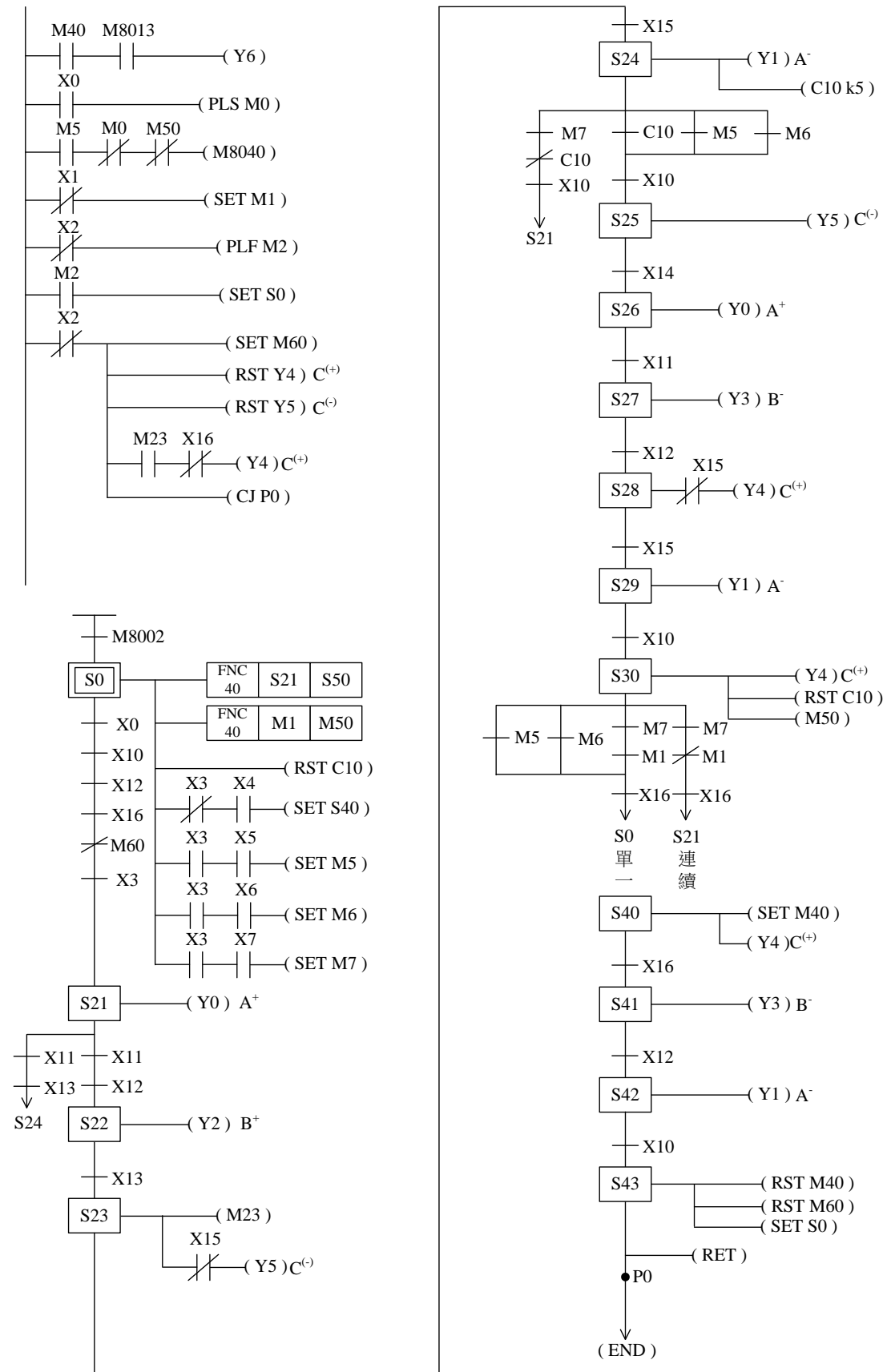

圖2-20 模式a SFC圖

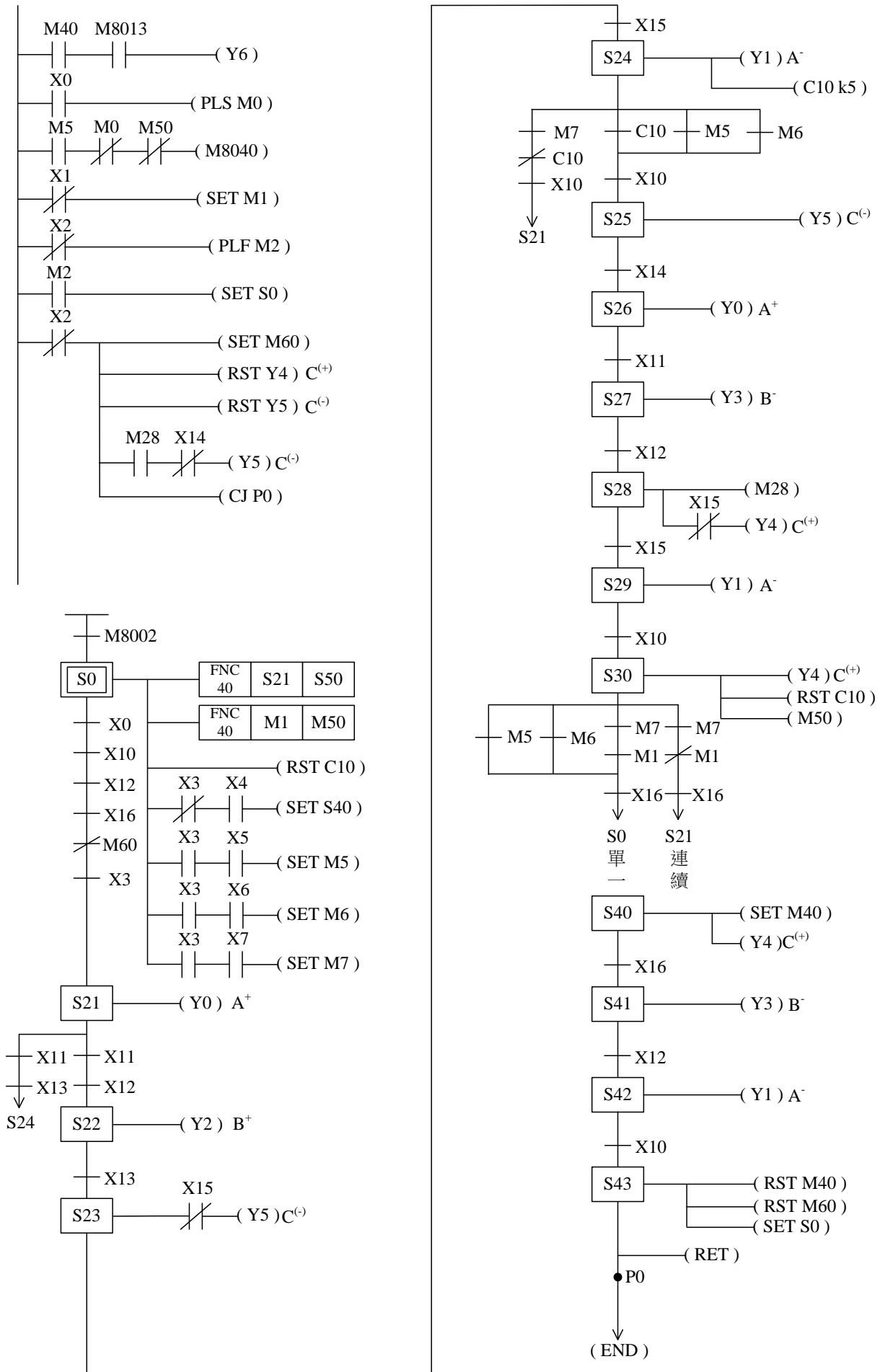

圖2-40 模式b SFC圖

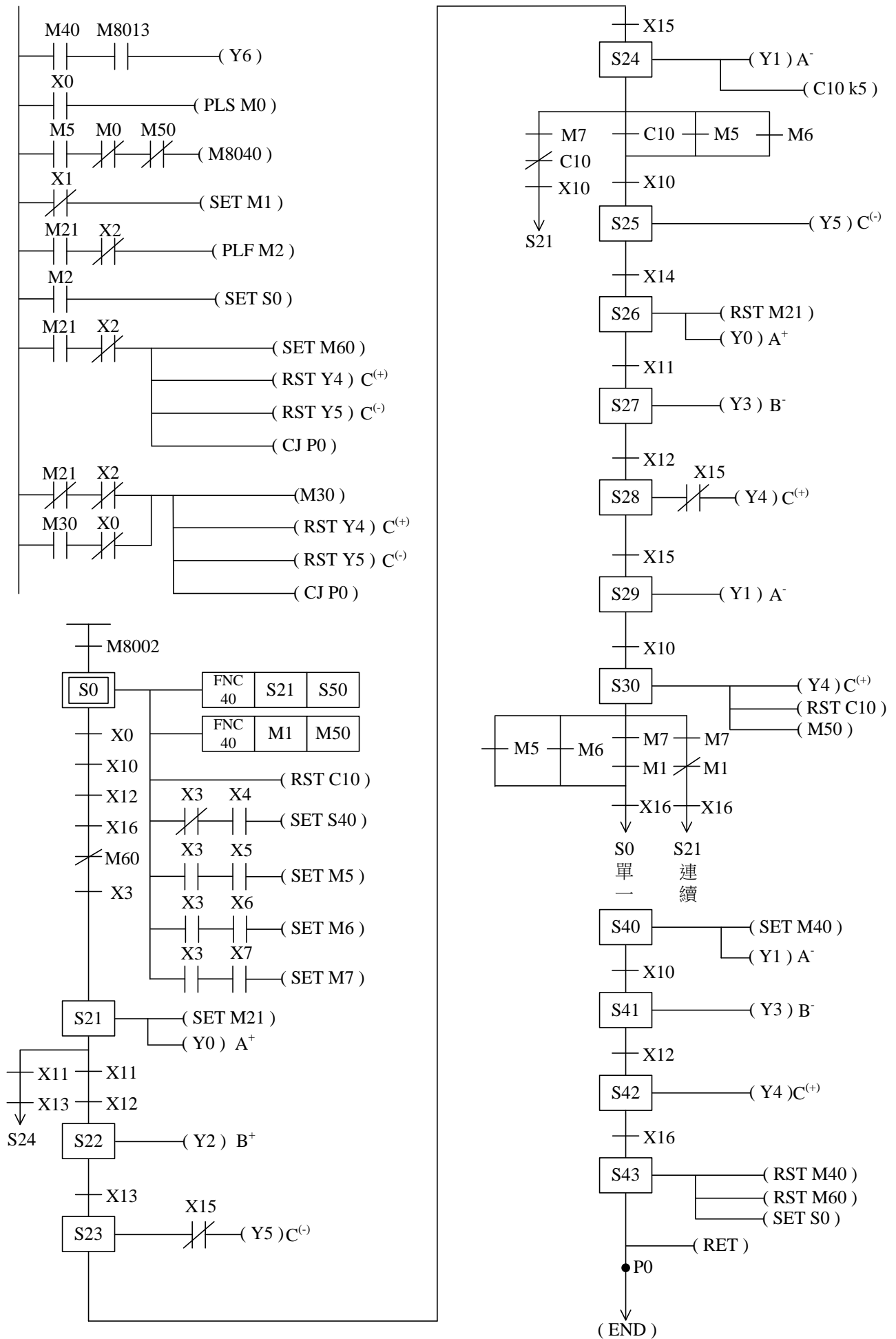

圖3-24 模式a SFC圖

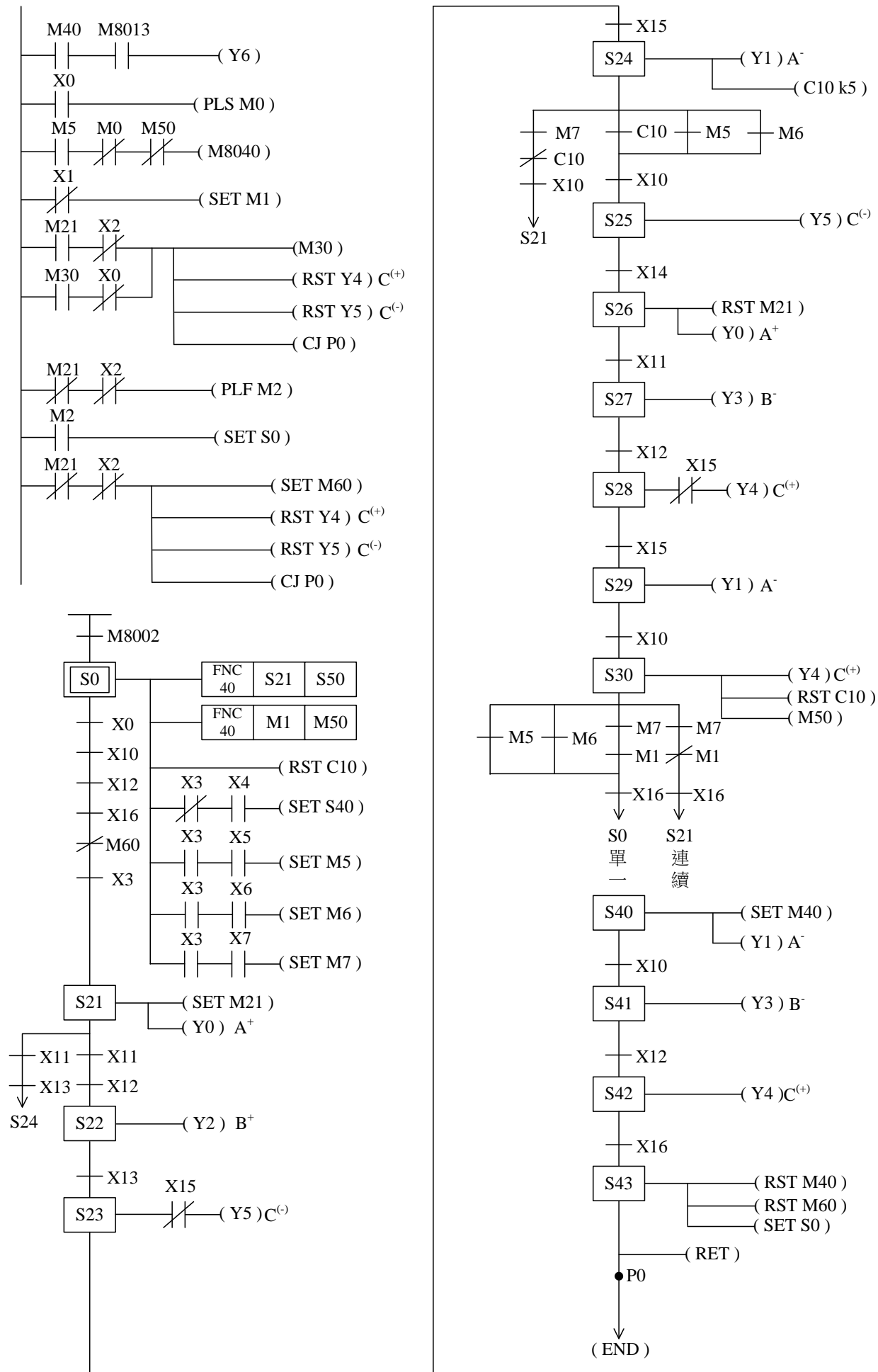

圖3-48 模式b SFC圖

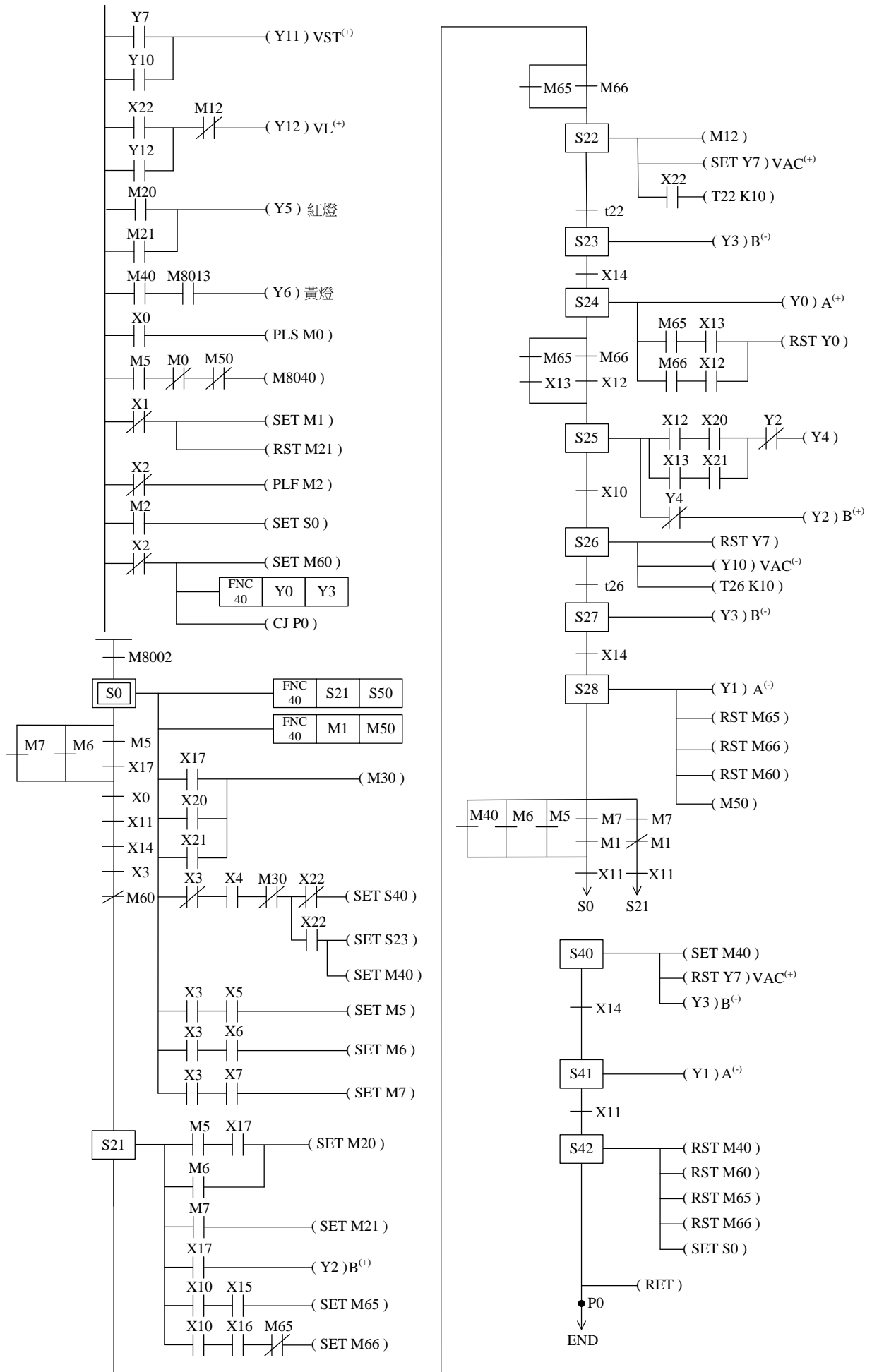

圖4-24 模式a SFC圖

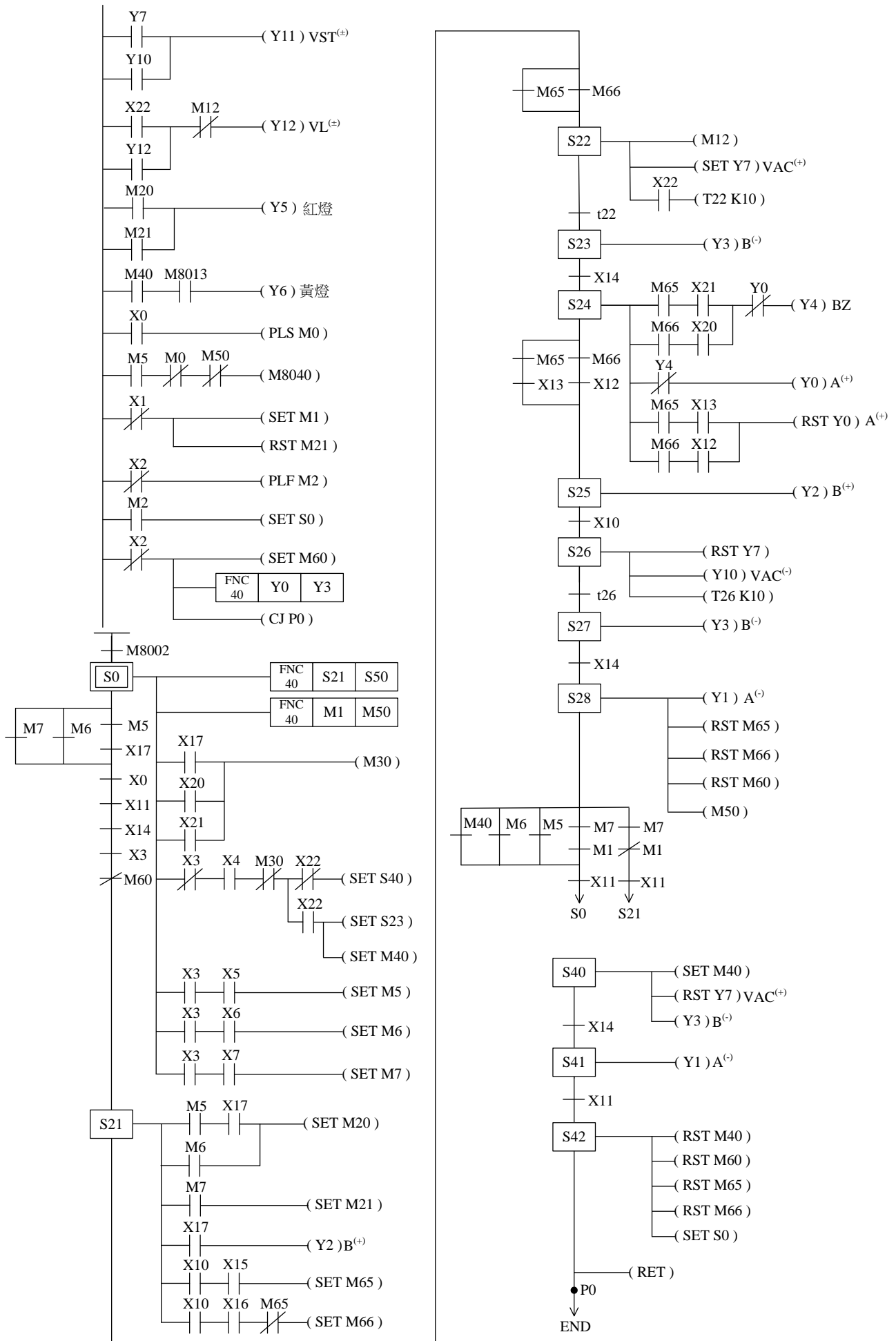

圖4-49 模式b SFC圖

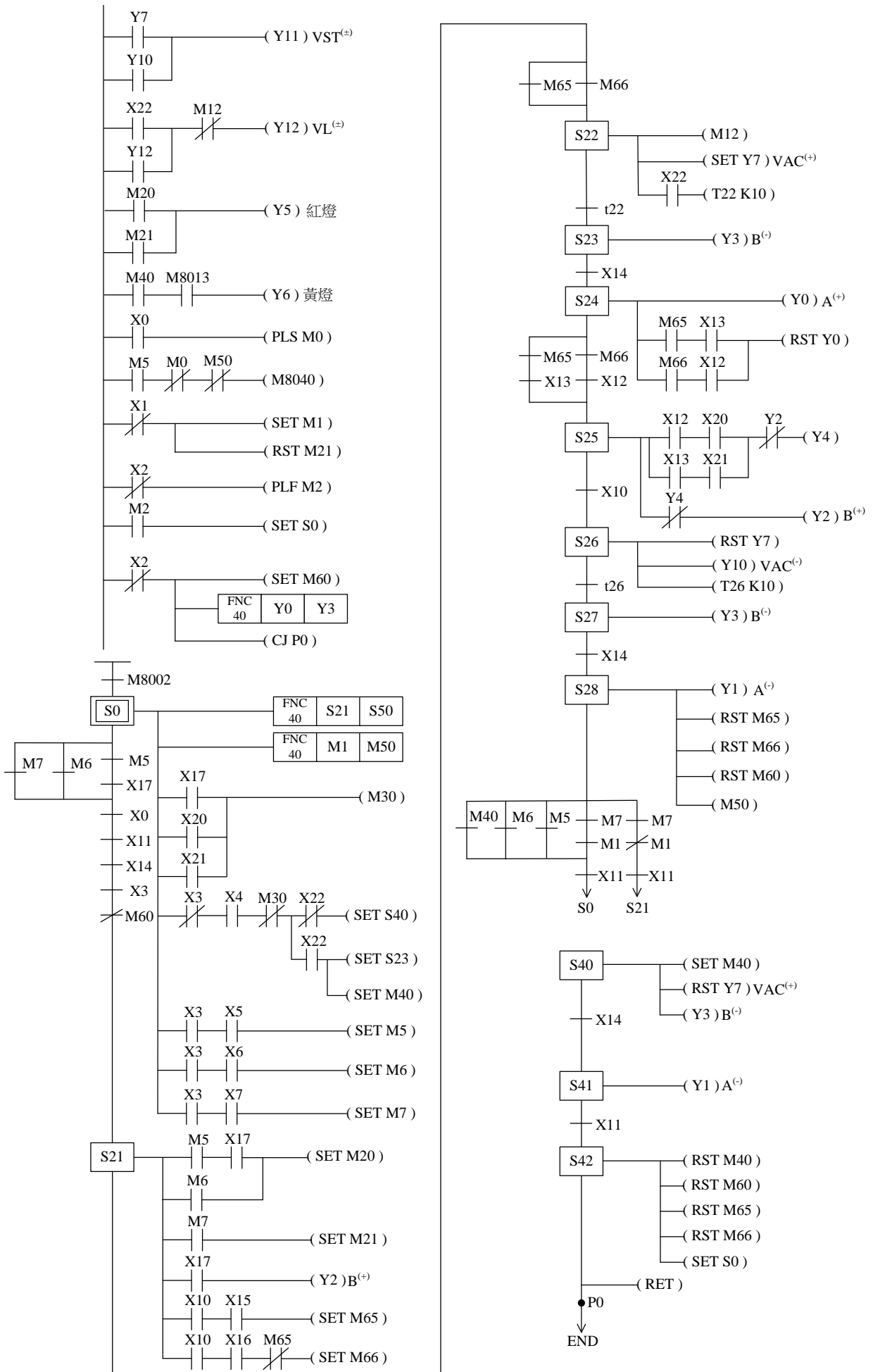

圖5-18 模式a SFC圖

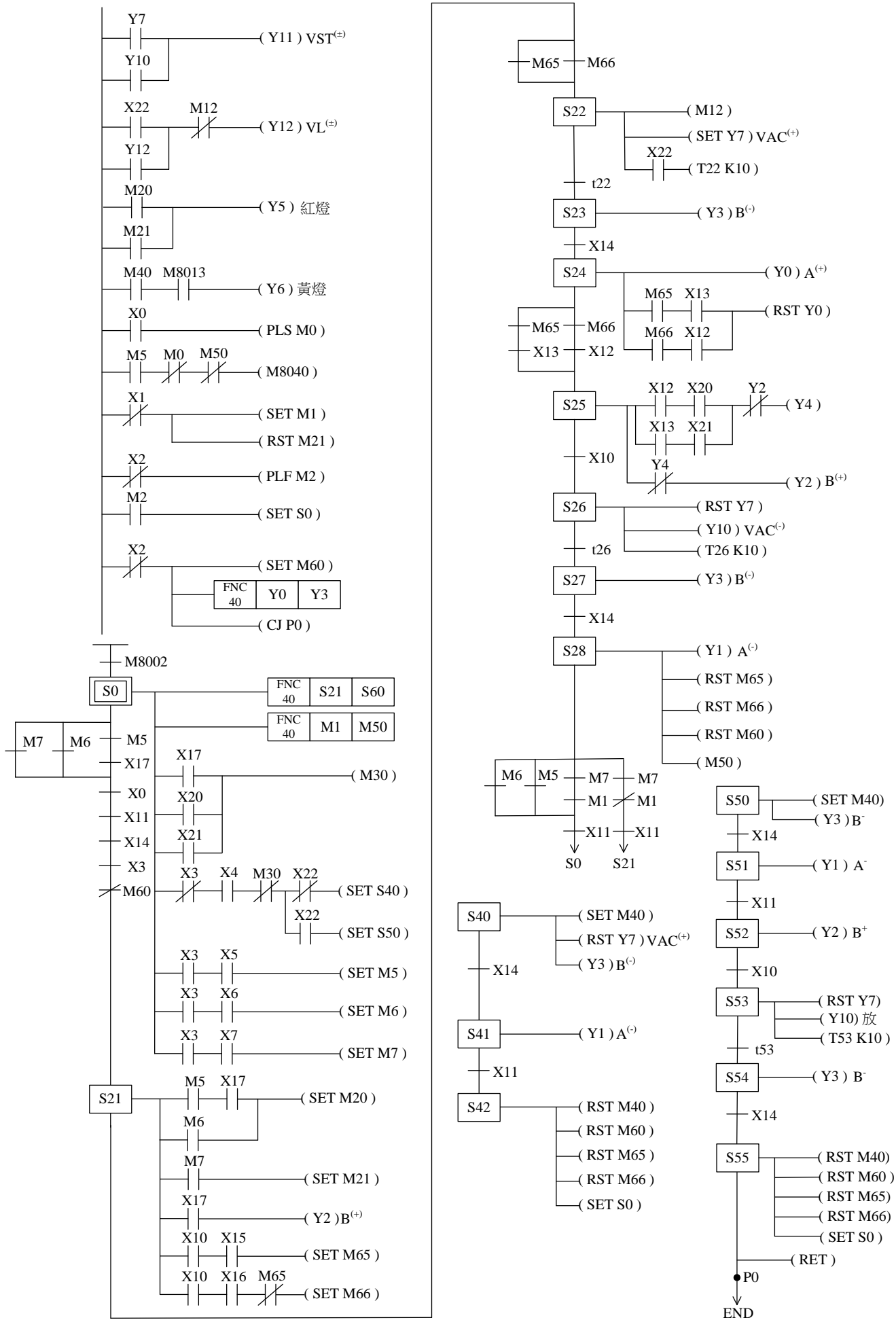

圖5-36 模式b SFC圖

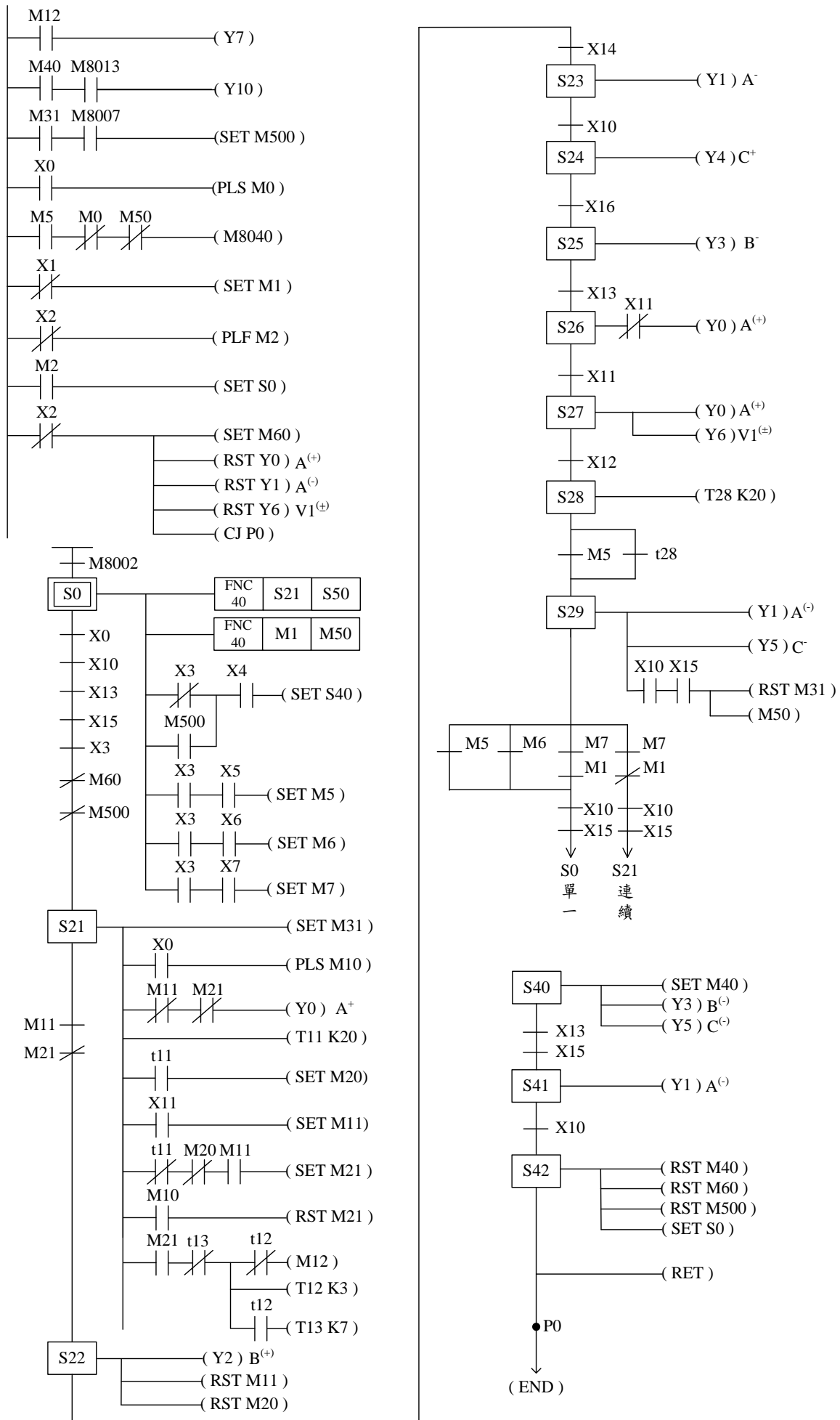

圖6-18 模式a SFC圖

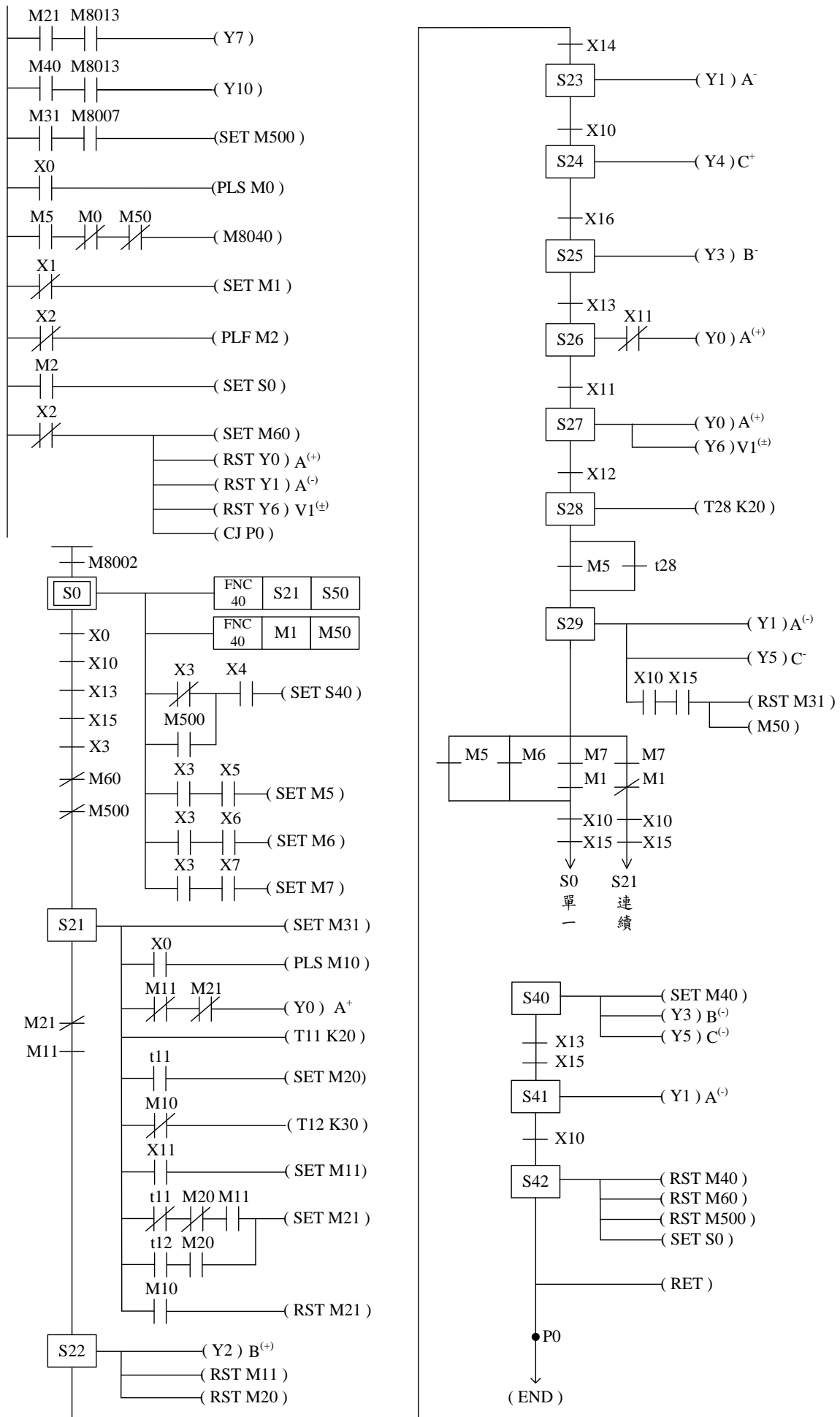

圖6-35 模式b SFC圖

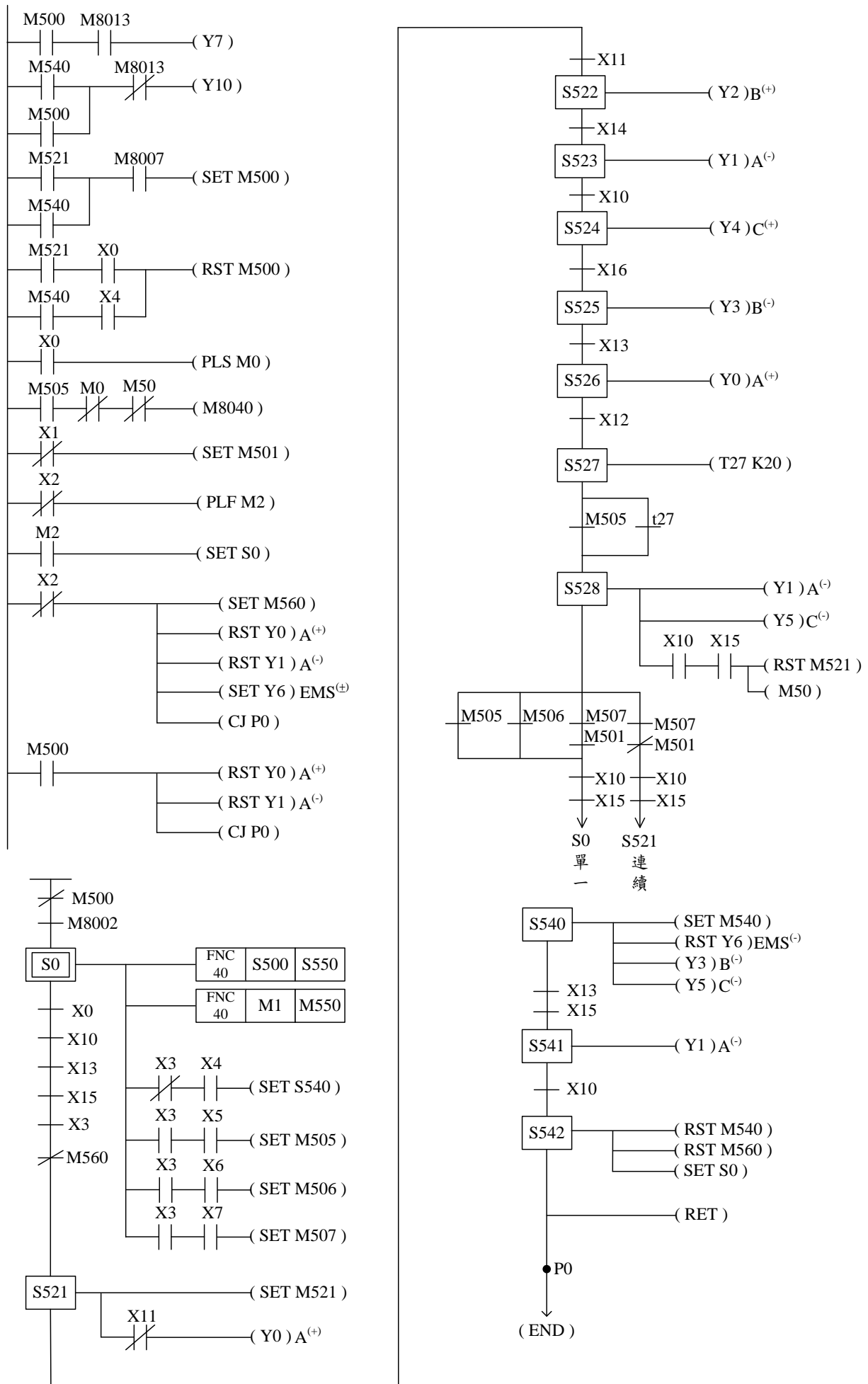

圖7-5a 電路圖

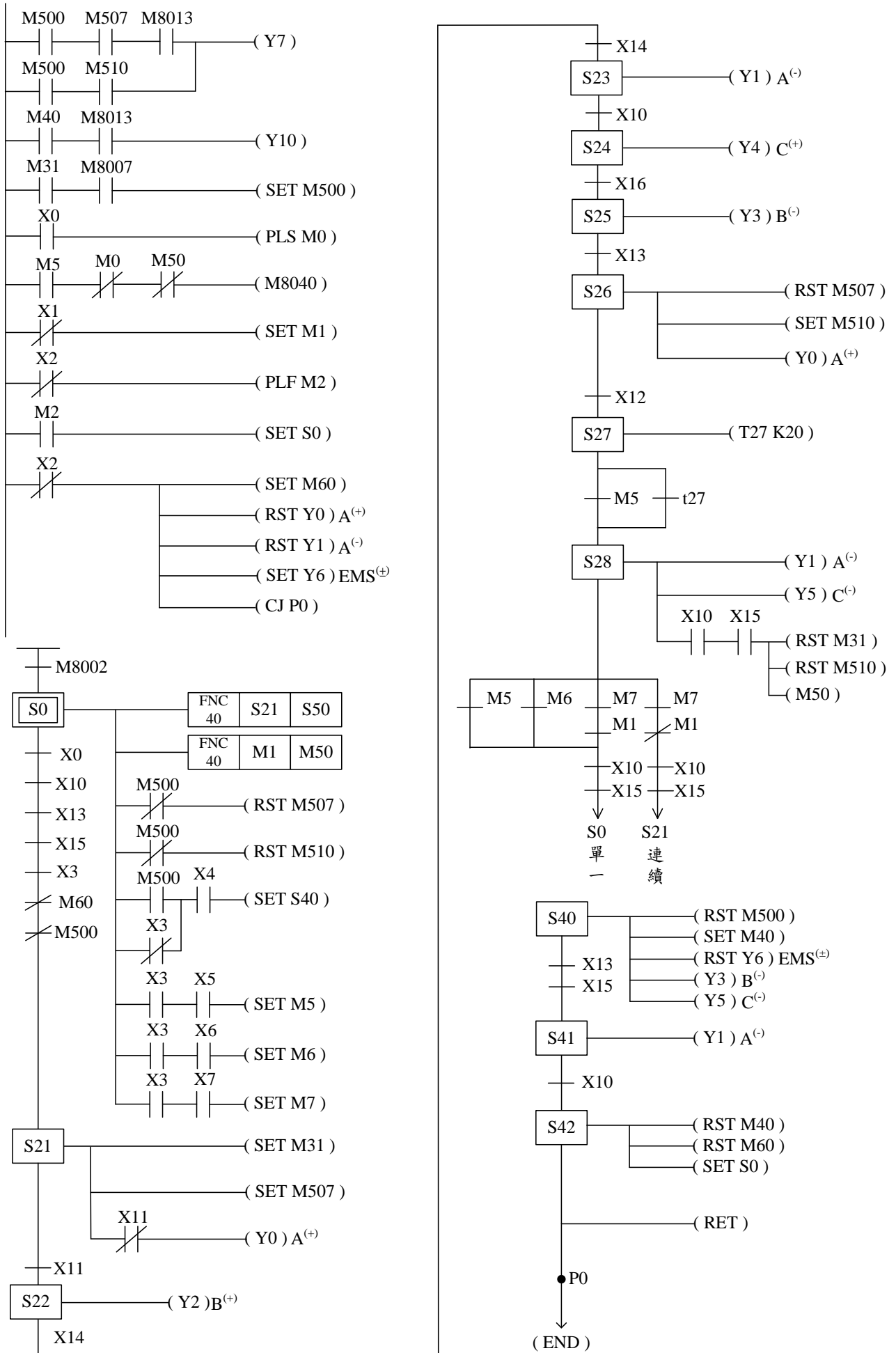

圖7-5b 電路圖(另解)

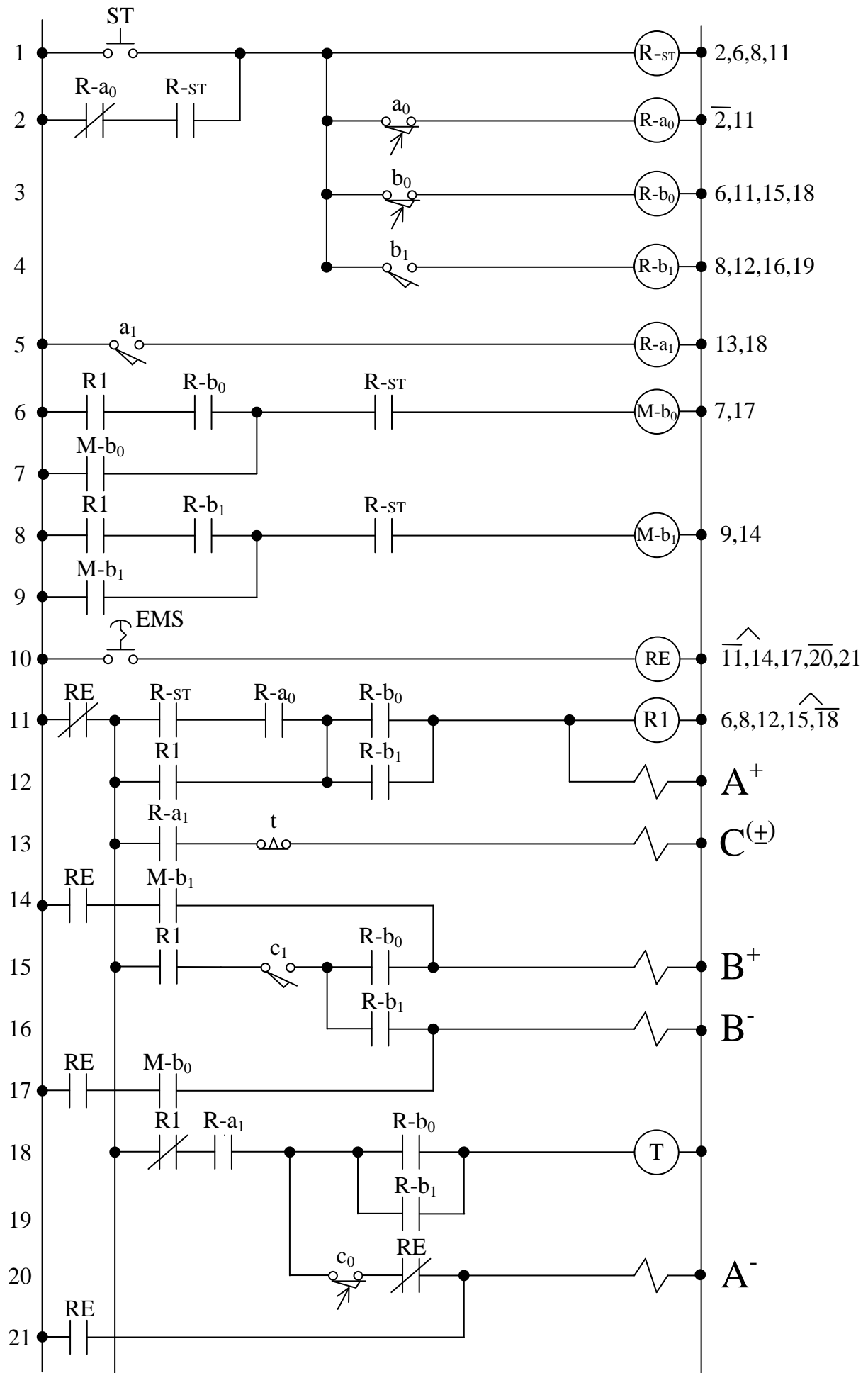

圖8-3 電路圖

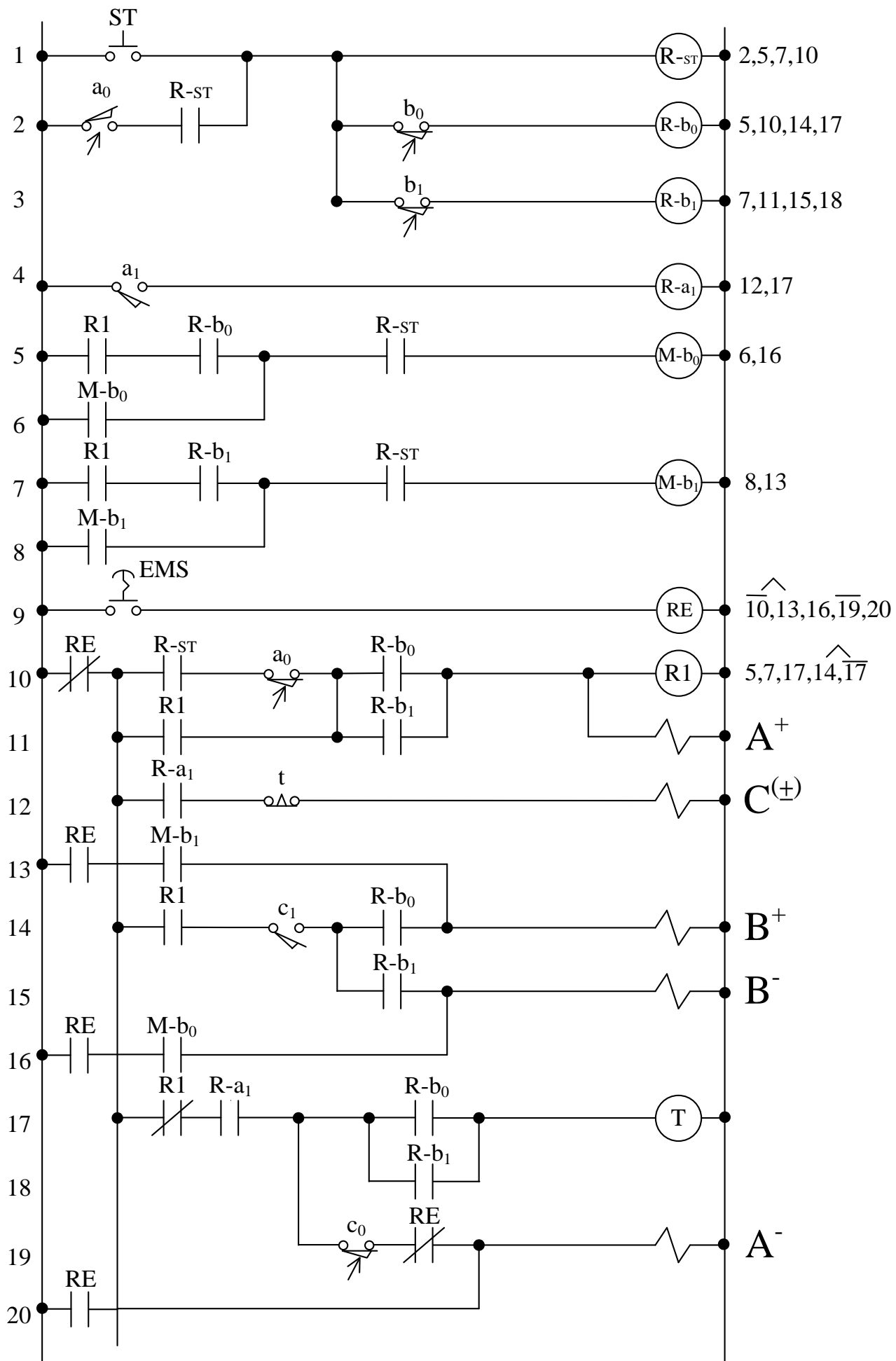

圖8-3b 電路圖(另解)

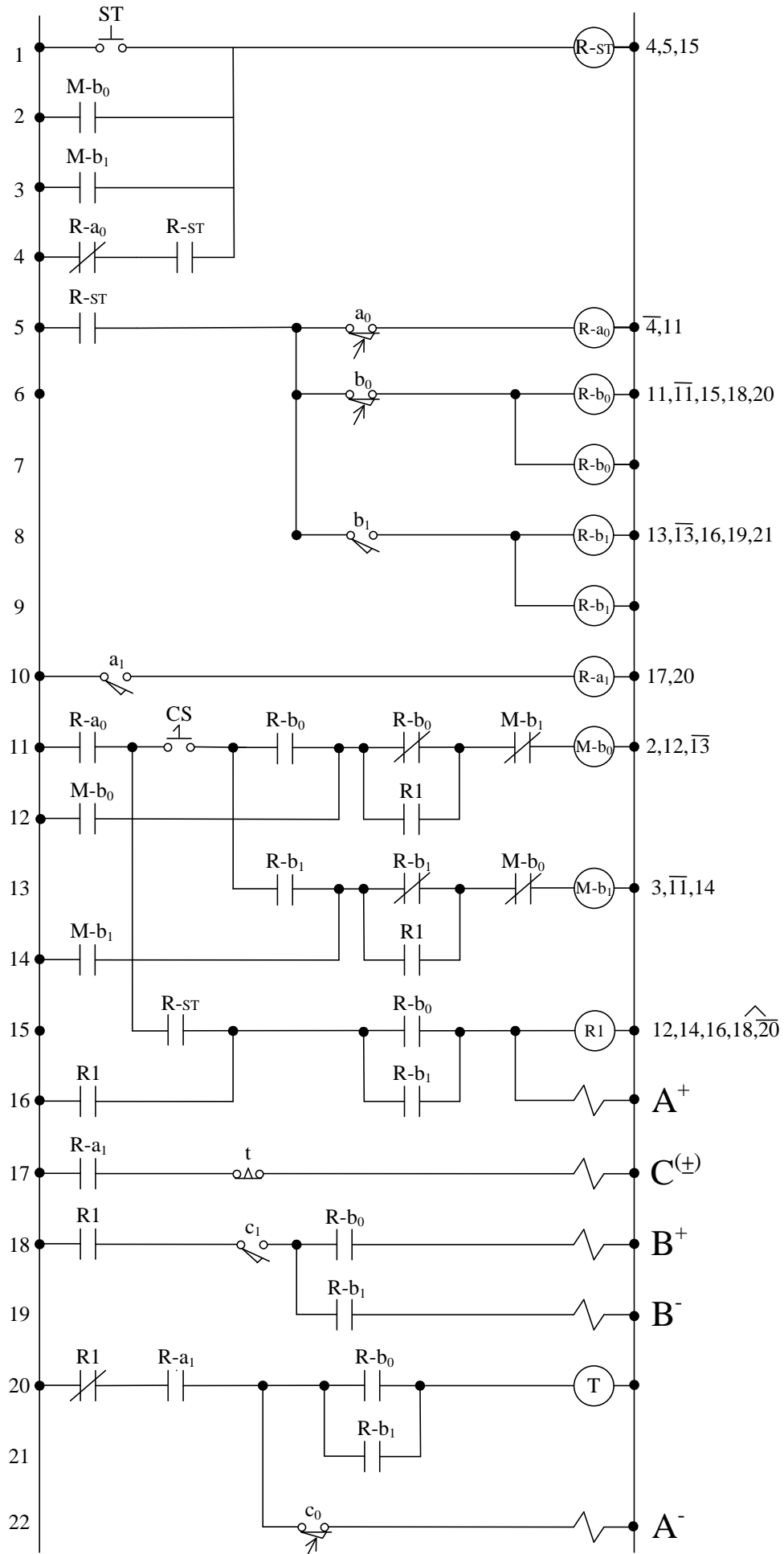

圖9-5 計數反覆動作回路

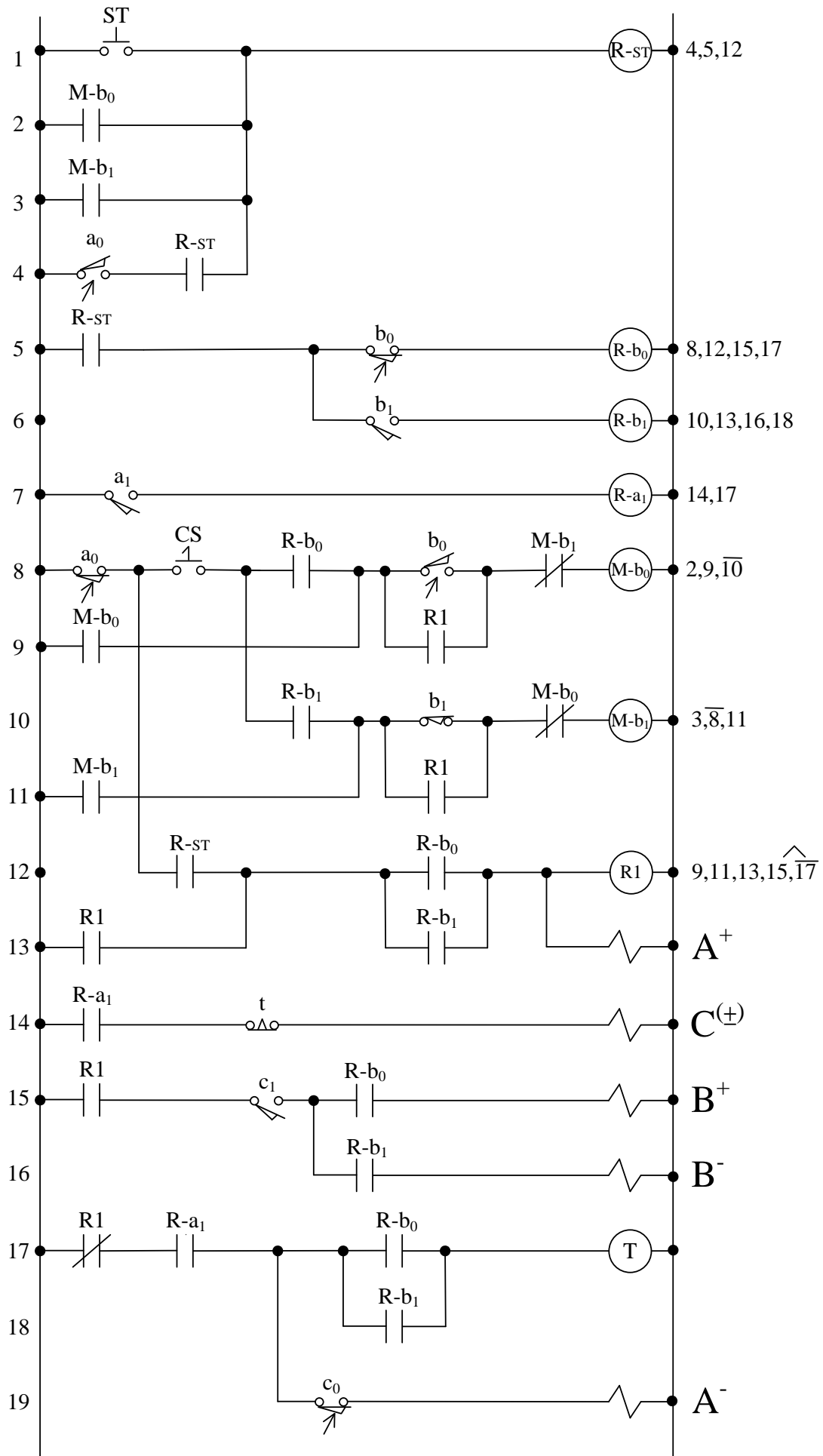

圖10-4 計時反覆動作回路

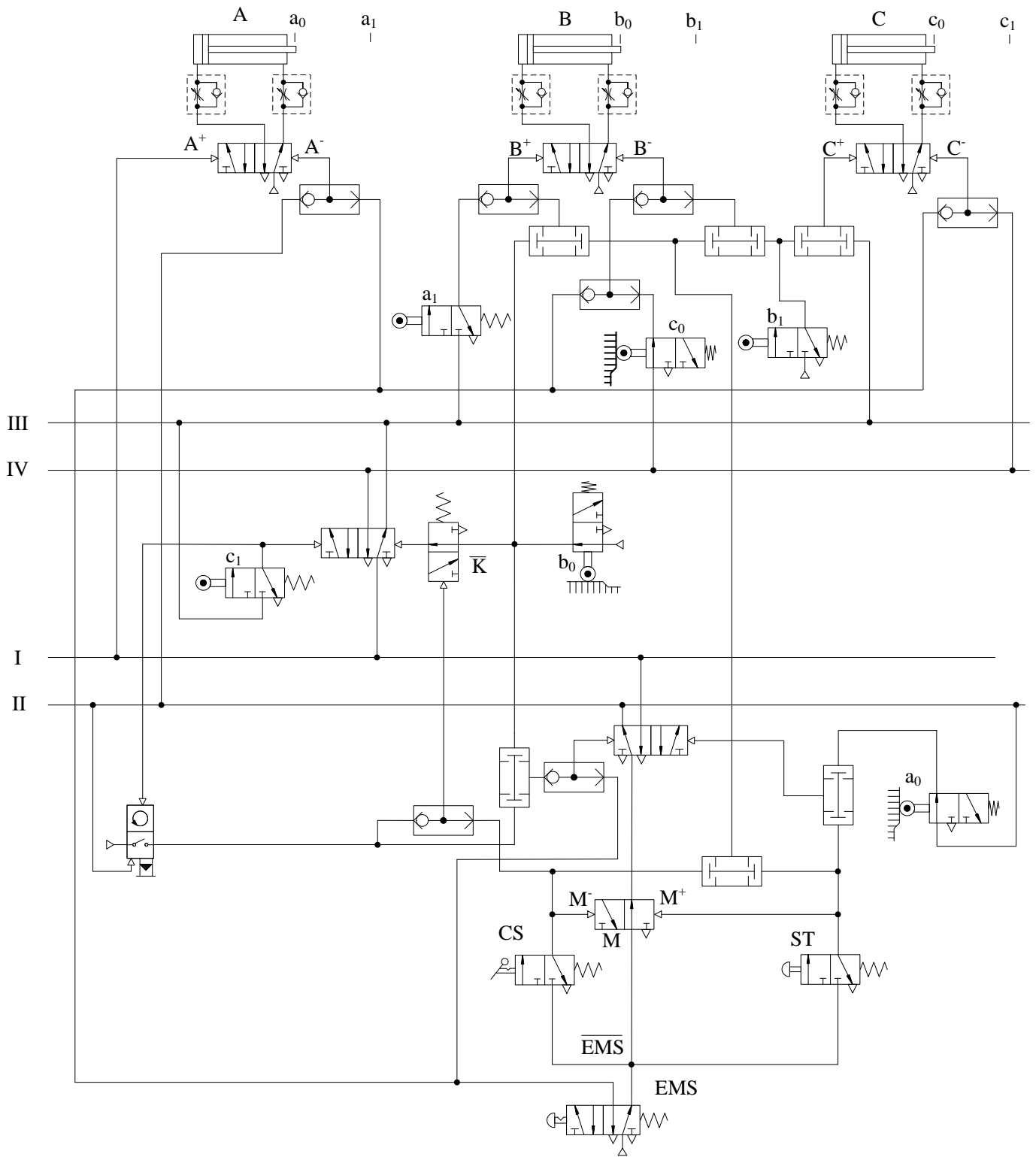

圖11-9 順序發生器迴路

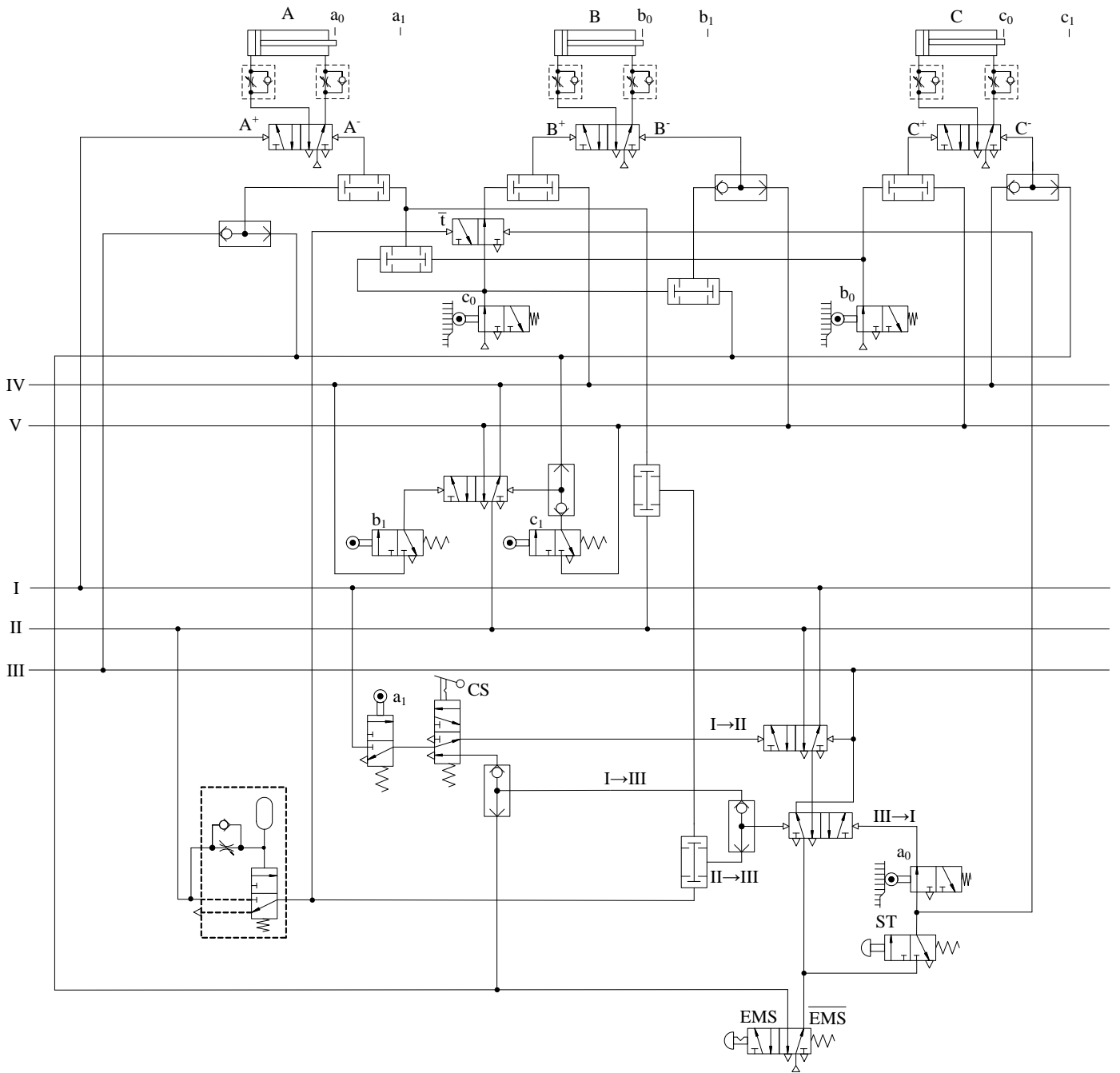
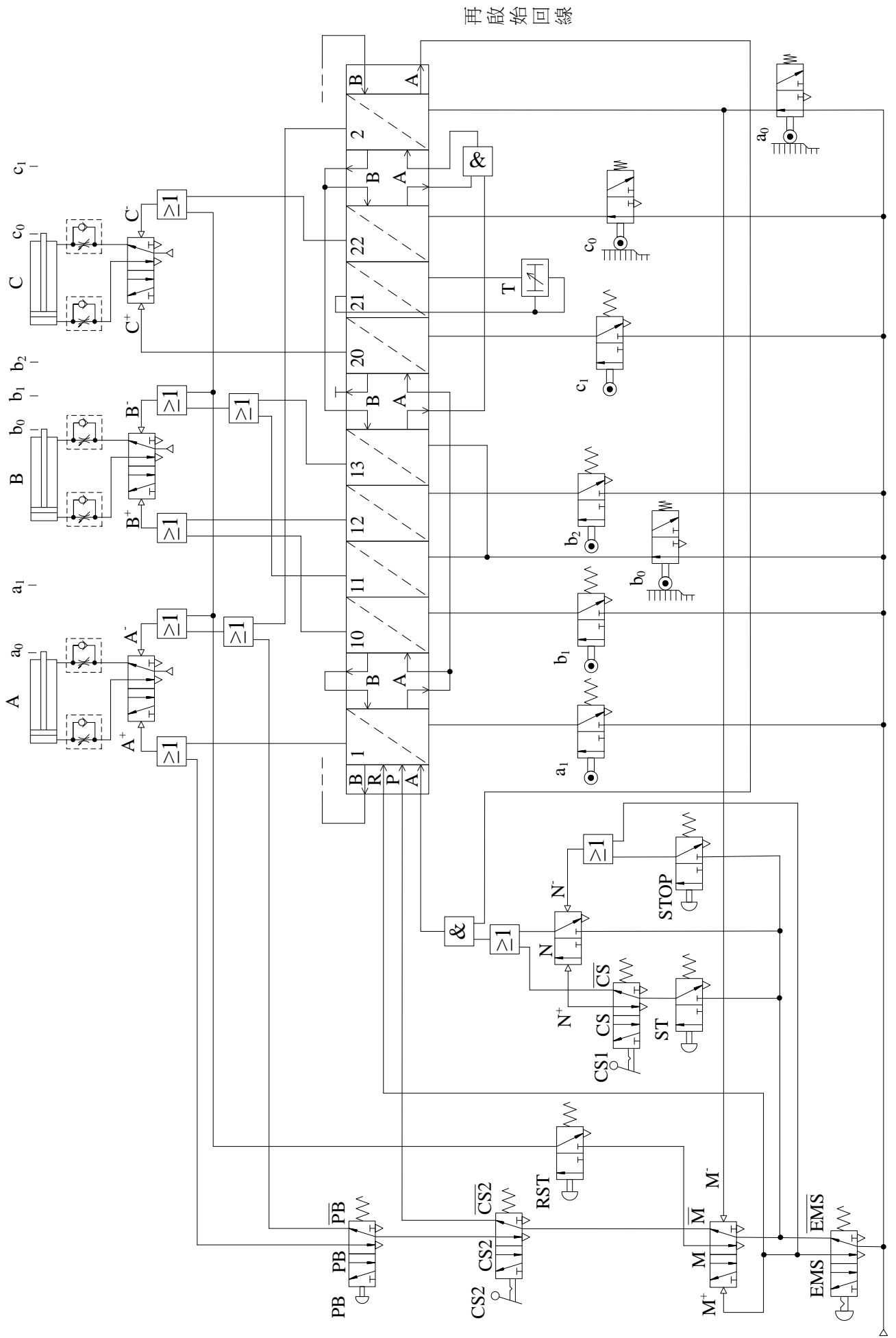
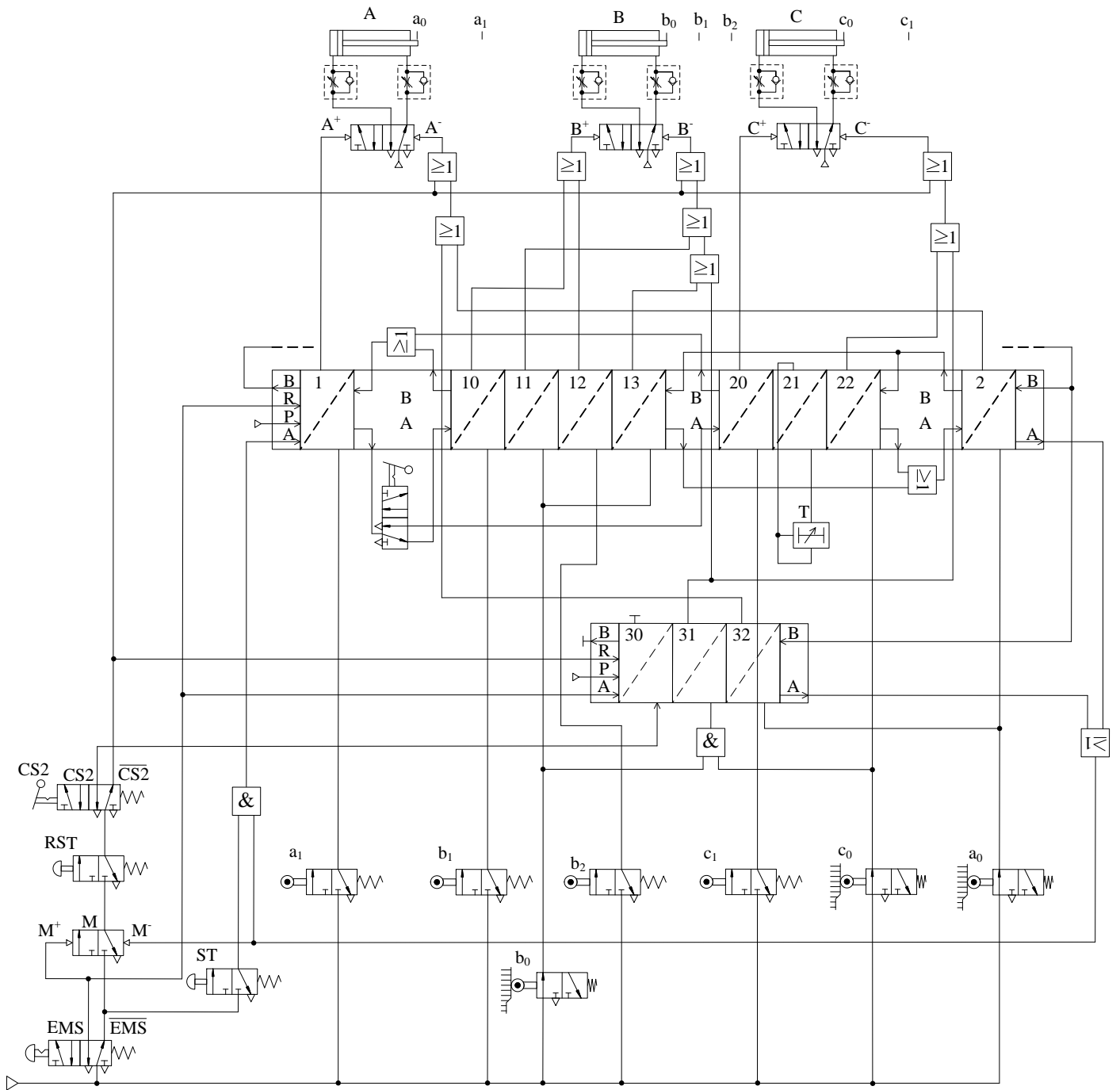

圖 12-8 順序發生器迴路